

PC TEST POINTS

PRINTED CIRCUIT WIRE FORM TEST POINTS

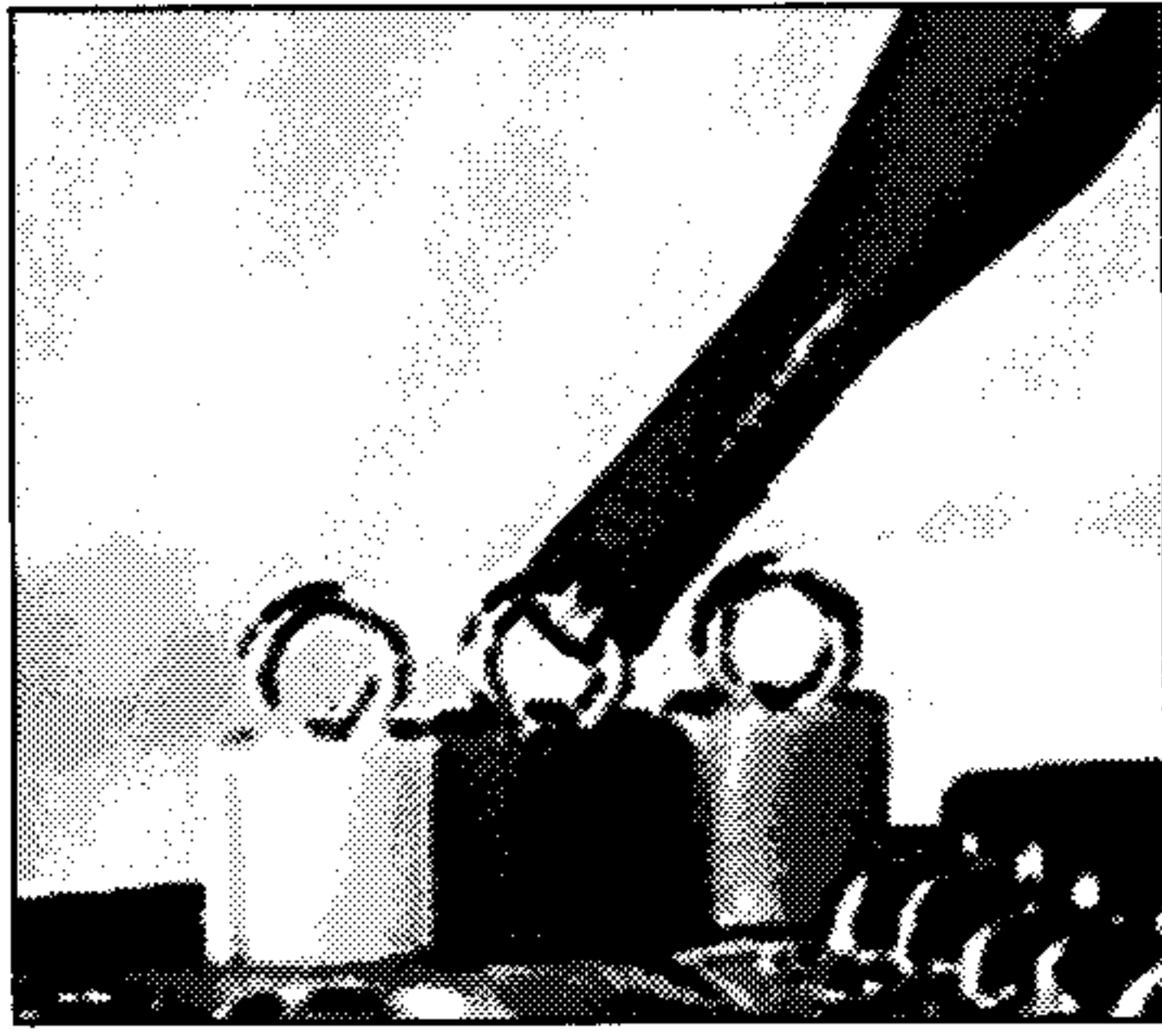

- COLORED CODED PC TEST CLIPS
- BOOST VISIBILITY AND IDENTIFICATION
- EASY POLARIZATION
- SECURE GRIPS FOR GRABBERS, HOOKS, ALLIGATOR CLIPS, PROBES OR TIPS
- AVAILABLE IN STRIPS OF FROM ONE TO THIRTY POSITIONS

707-5401-XX-XX PC TEST POINTS

BASIC PART NO. NO. OF COLOR POSITIONS PER STRIP

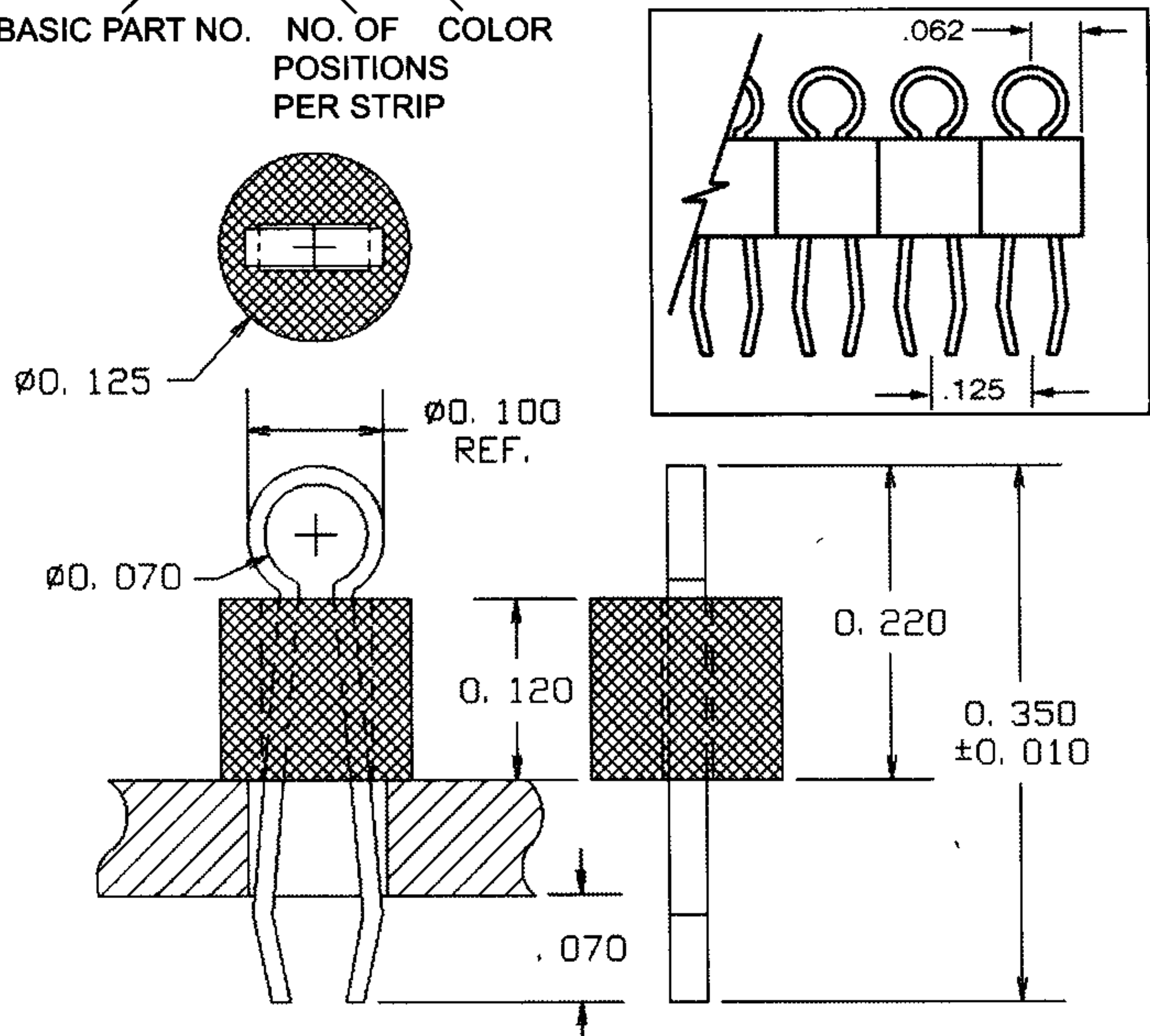

SPECIFICATIONS:

Mtg. Hole: .063" Dia. Hole

Material: .015"x.030 Phosphor Bronze Alloy, Electro-Tin finish

Collar: 30% Glass filled polyester

BLK	BRN	RED	ORN	YEL	GRN	BLU	PUR	GRY	WHT
10	11	12	13	14	15	16	17	18	19

For hand tool to facilitate cutting, gripping, and insertion of test points, order Concord P/N 707-5401

707-5403-XX-XX PC TEST POINTS

BASIC PART NO. NO. OF COLOR POSITIONS PER STRIP

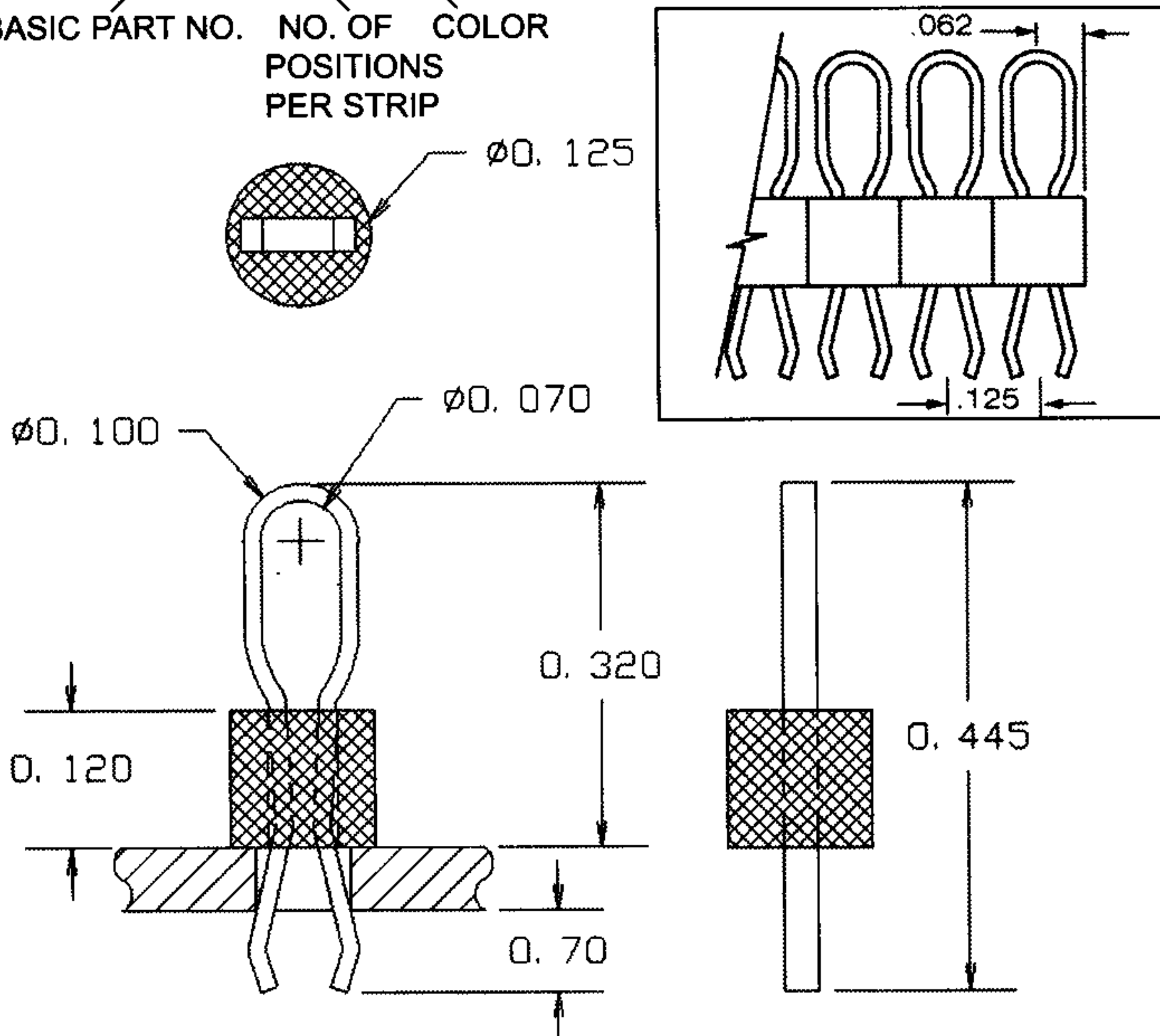

SPECIFICATIONS:

Mtg. Hole: .063" Dia. Hole

Material: .015"x.030 Phosphor Bronze Alloy, Electro-Tin finish

Collar: 30% Glass filled polyester

BLK	BRN	RED	ORN	YEL	GRN	BLU	PUR	GRY	WHT
10	11	12	13	14	15	16	17	18	19

For hand tool to facilitate cutting, gripping, and insertion of test points, order Concord P/N 707-5403

707-5402-XX-XX PC TEST POINTS

BASIC PART NO. NO. OF COLOR POSITIONS PER STRIP

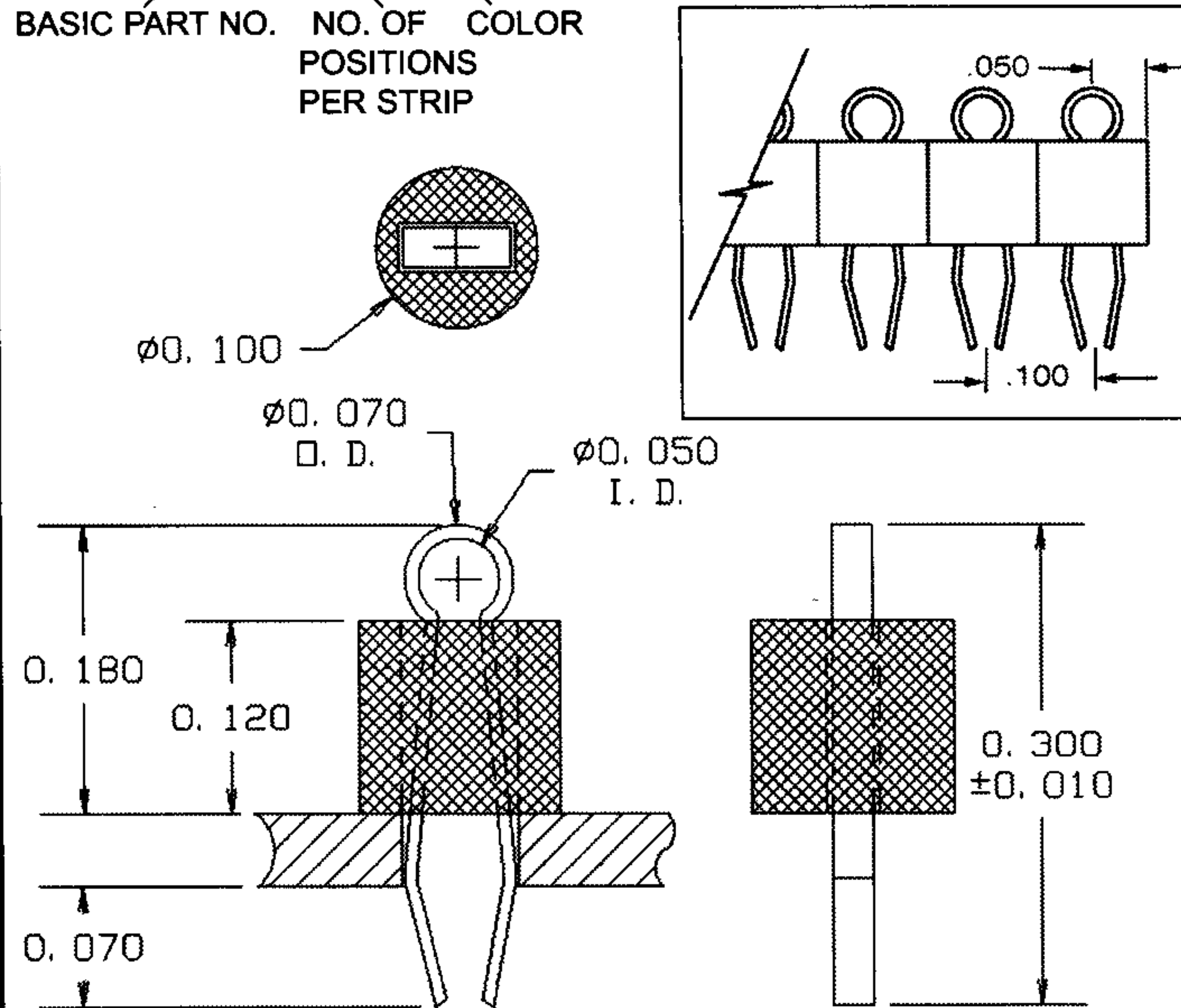

SPECIFICATIONS:

Mtg. Hole: .035" to .042" Dia. Hole

Material: .010"x.020 Phosphor Bronze Alloy, Electro-Tin finish

Collar: 30% Glass filled polyester

BLK	BRN	RED	ORN	YEL	GRN	BLU	PUR	GRY	WHT
10	11	12	13	14	15	16	17	18	19

For hand tool to facilitate cutting, gripping, and insertion of test points, order Concord P/N 707-5402

FOR ADDITIONAL SIZES AND MATERIALS, CONTACT FACTORY

